

## **Making Better Use of Information: Aiming Towards “True North”**

Kathryn A. S. Lancaster, Ph.D., CPA<sup>1)</sup>, William J. Bellows, Ph.D.<sup>2)</sup>

<sup>1)</sup> Orfalea College of Business California, Polytechnic State University 1Grand Avenue, San Luis Obispo, CA, USA 93407 (klancast@calpoly.edu)

<sup>2)</sup> The Boeing Company 6633 Canoga Ave Canoga Park CA 91303 (william.j.bellows@boeing.com)

### **Abstract**

“If I only had the right information, I could make an informed decision.” How often have you heard that comment? With the information technology currently at our disposal, one would think that the right information would be available and that all decisions would be sound. However, users must still determine what data provides valuable information and what are the limitations of the soundness of a decision. What has been missing from most decision models is prediction awareness, as well as a “true north” compass reading for the organization, based on goals that reflect the system within the organization and that within which the organization operates. We propose that it is easier to identify what information is needed to stay on course (*true north*) then make that information available to all decision makers, who can then make more holistic informed decisions when such a compass reading exists.

Keywords: systems thinking, holistic thinking, W. E. Deming, decision-making process, decision synergy, management by means

Kathryn Lancaster is an Associate Professor at California Polytechnic State University. Her areas of research are teaching pedagogy and the role of accounting in reporting social and environmental responsibilities.

William Bellows is Process Leader for the Enterprise Thinking Network at Rocketdyne, Canoga Park, a division of The Boeing Company. He is also one of the founding members of the In2In Thinking Network.

## 1. Introduction: “Present State” and “Future State”

Technological advances of the past decade have greatly facilitated relationships between companies and their stakeholders. Personal computers, pagers, cell phones, and personal digital assistants have provided such connections. The coming years will surely see improvements in these technologies and perhaps the introduction of subsequent disruptive technologies. Given the ability of technologies to streamline connections, plus the availability of increased quantities of information, the missing link to the value proposition of this information and technology may well be the role of the individuals interpreting this information and the importance of considering both upstream and downstream impacts on the organization based on a holistic goal, which becomes *true north* for the company.

We define the “present state” as one in which organizations suffer from a growing disregard for the economic losses resulting from strained relationships between individuals, be they employees, suppliers, customers or management. Often missed in this web of relationships is the connection between these organizations and the communities in which they operate and the reliance on a healthy ecology. W. Edwards Deming [1] referred to this “present state” as the “prevailing style of management” with attributes that include a short-term focus on the bottom line and a tendency to manage the pieces in a mechanistic manner, with little regard for synergistic impacts. The net result is often what is feared most – sub-optimization is inadvertently encouraged and highly regarded organizational oneness is undermined. Add to these attributes a deterministic perspective on analyses and decisions, where in both cases the results are planned to be exact and without failure. There is little room for uncertainty in such an atmosphere of firmness. Nor can there be much room for learning, other than learning how to avoid the implications of failure should the results not follow as planned.

Few organizations operate without many of the limitations and implications of the prevailing style of management. Their success may well be aided by similarly run competitors who themselves are unaware of alternative outcomes. However, there are a few organizations that manage with a high regard for synergy, between the people within its system and between the elements of the products or services it delivers to its customers. Such an organization is comprised of individuals who see the web of relationships and act upon this awareness with decisions on how to better manage resources. In doing so, holistic considerations are routinely captured in the decision-making process. Instead of the unspoken deterministic nature that characterizes the “present state,” individuals in this organization anticipate variation in outcomes and gain insight from this systemic behavior for what to expect in the future. The rigidity of determinism is replaced by the flexibility and humility of learning how to anticipate and manage uncertainty. This “future state” of operation offers the competitive advantage of positive synergy, wherein an organization would be seen to be more than the sum of its parts. By comparison, Deming often lamented at how organizations could possibly be less than the sum of their parts. He was no doubt mindful of the possibilities of a “future state” and frustrated by the “present state.”

This paper follows several years of independent research by the authors, who met in the summer of 2001. After comparing past and present experiences in accounting and engineering, we noticed the similarities in our findings and our views of the future. We both saw the shortcomings of “present state” organizations and the untold losses they produce. We propose a glimpse of the future in this paper. It is a glimpse of organizations that can make better sense of information when they aim towards their own true north. True north is defined as the organization’s strategic goals that encompass various stakeholder expectations. For example, Johnson and Johnson’s Credo has guided their decisions for over 50 years. It ranks the company’s responsibilities in the following order. First and foremost is the company’s responsibility to the individuals who use their products. Its second responsibility is to employees. This is followed by the company’s responsibility to be a good neighbor in the communities where it resides, which includes protecting the environment. The final responsibility is to provide a fair return to stockholders.

Benefits of such a focused perspective include the ability of the organization to do more with less, certainly a goal of management teams as well as individuals in their personal lives. For organizations, our vision of a “future state” naturally includes higher profitability, greater customer loyalty, and higher employee morale. The

transformational path for an organization begins with the realization that such a better place exists. Movement towards the “future state” is achieved one person at a time, when individuals elect to take place in the journey and manage the elements of the organization as a system with a great regard for non-deterministic results. The individual journeys involve better thinking about these possibilities.

The next section briefly reviews relevant literature on better thinking. We conclude the paper with examples of how better systemic and holistic thinking is being implemented in organizations. These examples offer a proposal for the prevailing style of management to evolve to a state where more stakeholders are included in the initial decision-making process and there is greater acceptance of the assumptions of predictions. Data then becomes information that is used to support and further holistic decisions, thereby allowing an organization to articulate, then hold course on its true north.

## 2. Discussion of Relevant Literature

We briefly summarize the research of various system thinkers whose work we consider invaluable to better decision making. We also touch on the work of several individuals who go beyond the traditionally considered business relationships and connections by including ecological impacts in their decision process. We believe there is a vital need to link these apparently unconnected efforts to better manage organizations and the environment.

Our summary begins with Deming, a self-described “consultant in statistical studies.” We continue with de Bono, who emphasizes awareness of the flow pattern that connects elements together in his water logic theory. We then touch upon the efforts of Genichi Taguchi, whose concept of *minimizing loss to society* can readily be expanded upon as a framework for environmental awareness and more holistic decision making. We also reference the thinking of H. Thomas Johnson and include his recent thoughts on management by means. Trained as a managerial accountant and educator, Johnson now studies the type of information needed to support systems thinking.

This framework of systems thinking is used to discuss the efforts of some ecobusiness leaders. We touch upon the thoughts of Amory Lovins, Allan Savory, Karl-Henrick Robert, and William McDonough. Lovins is founder of the Rocky Mountain Institute, an eco-business consulting organization. Savory is founder of the Holistic Resource Management Institute, an organization that began by working with farmers and ranchers to bring sustainable thinking into their practices. Robert is the guiding light behind The Natural Step, a movement begun in Sweden that brings together people concerned about the environmental impact of today’s consumption patterns. Architect McDonough teamed with chemist Braungart to help firms identify and implement sustainable practices.

### 2.1 Systems Thinking

We consider Deming’s management theory to be foundational to holistic decision making. Two statements by Deming are offered to provide a framework for our recommendations. The first reflects on the role of information, which includes data.

*The object of taking data is to provide a basis of action. [2]*

*The theory of knowledge helps us to understand that management in any form is prediction. [3]*

The second thought offers a context for learning as when the ensuing action (often a decision among alternatives) becomes a foundation for charting a course of direction. These statements offer essential perspectives for consideration of the role of information in businesses and how to integrate the accelerating advances in information technology with potential advances in *better thinking about thinking*, all the while maintaining an organizational focus on true north.

Deming used the term “the prevailing style of management” [4] to describe the administration style of

organizations that are characterized by activities that unwittingly promote local sub-optimization. The management actions that unknowingly sustain such non-systemic behaviors are driven by an unrecognized and, therefore, un-stated, set of beliefs and assumptions. Among the telltale signs of these belief systems are management practices that overlook, if not underestimate, non-linear causal loops. Instead, organizational actions are viewed as linear (cause and effect) and orientations such as “upstream” and “downstream” are used to denote the endpoint positions within it, in a unidirectional flow.

Contrast the linear view of organizational actions and activities with the recursive model that Deming advocated (Figure 1), where a so-called “zeroth stage” action sets the system in motion with the initial design idea. Organizations that follow the Deming management model are characterized by a widespread awareness of non-linear system dynamics, especially as related to the “plan-do-study-act” (PDSA) learning cycle [5]. These attributes, coupled with a high value placed on maintaining a sense of unity (one company) that extends beyond the organization to include suppliers and customers, result in lower levels of sub-optimization and, therefore, high levels of profitability.

Transformation of an organization, from one that resembles the win-lose environment of the prevailing style of management to one that is Deming-based (win-win), has been shown repeatedly to require systemic change [6, 7]. Vital to this transformation is better thinking by individuals in these organizations about systems, variation, knowledge, and psychology. In such an environment of enlightened thinking, all decisions are openly acknowledged to be predictions of future results, be they as complicated as planning a business strategy or as casual as planning how to go home after work. Quoting again from Deming,

*The simplest plan – how may I go home tonight – requires prediction that my automobile will start and run, or that the bus will come, or the train. [8]*

Added to the concept of planning how to get home is an inherent variability in all aspects of the trip. For example, when using a rail service, one predicts that a train will arrive at the station at a given time and further anticipates that the arrival time will vary from day to day. Such results are also known to be a by-product of a system of interdependent elements. In terms of a manufacturing example, it follows that the quality of the weld that joins two ducts will vary about the perimeter of the weld, as well as from duct set to duct set. It also follows that this variability is more than a reflection of the welder who operates the equipment. Looking more broadly at the system, the list of interdependent elements extends to include the quality of the weld wire, the cleanliness of the surfaces to be joined, and the purity of the gases used to produce the flame. A wider view of the system would prompt the discovery of a growing number of elements. An organization conducive to such thinking offers freedom for employees make better sense of information - that is, to innovate and learn from ever evolving theories. Predictions that fall within a predetermined expectation zone leave the theory intact, ever ready for future use. Predictions that extend beyond our expectations will prompt an update to the theory. Organizational learning follows when the theories are routinely updated, widely shared, and integrated. Those organizations that have embraced Deming’s philosophy have become models for successful transformation in many areas. These may well be the most likely organizations to adopt better thinking about thinking. Herein lies a vast investment opportunity for many accounting professionals.

The proposed solution to the information utilization problem follows directly from the use of Deming’s management philosophy. Quoting from Chapter 4 of *The New Economics* [9], Deming states;

*The aim of this chapter is to provide an outside view - a lens - that I call a system of profound knowledge. The system of profound knowledge provides a lens. It provides a map of theory by which to understand the organizations that we work in.*

More specifically, Deming’s concept of a “system of profound knowledge” offers a framework in which one can better understand the organizational dynamics that can serve to hinder or elevate organizational learning. The elements of Deming’s system of profound knowledge consist of four parts and their interrelationships. In addition to the aforementioned elements of systems thinking, awareness of variation, and the theory of knowledge, Deming included psychology in his concept of profound knowledge. Awareness of psychology

offers insights into the behaviors of individuals and organizations in the presence of such non-systemic actions as blaming the welder for poor weld quality or the conductor for the late arrival of a train.

Systems thinking offers an array of perspectives and questions for decision makers to consider as they define strategies and set business directions. There may be no simpler question for an individual to ask than “what he or she is part of?” or, how do they fit in and how do their efforts fit in? Embedded in this inquiry is an explicit reference to a connection. The systemic thought is revealed by the concept “part of,” as opposed to “part.” Without the “of,” one could only inquire about the part, as in the question, “What is this part?” Given this inquiry, the connections would be lost as we return to a worldview of fragmented pieces that are not well understood to be connected. A system perspective is:

From Where? → This Part → Lead To?

In reference to the “from-this-to” sequence, questions such as “What is this part of?” “Where did this come from?” and “What will this lead to?” represent the essence of understanding relationships and inter-connections. The thinking revealed by these questions has been termed “water logic” by de Bono [10]. By contrast, references to events, parts are termed “rock logic.”

To view the world with rock logic is to view it in the form of an exploded view diagram - parts floating in space without any apparent connections. Rock logic also leads to disconnected, mechanistic perspectives, such as black/white, good/bad, and us/them. Compare this with water logic and its holistic, continuous perspectives. It follows that to view the world with water logic is to view it without seeing parts, as in the holistic sentiments of the circle of life and the oft-realized perspective that “what comes around goes around.” Based on water logic theory, a sound, holistic decision-making process considers the flow or connection between the elements located upstream and downstream. Further extension of such views reveals the world to be a pattern of relationships, where the upstream and downstream eventually join.

Relationships are also the emphasis of Taguchi, who defines quality as “the minimum of loss a product causes to society after being shipped” [11]. The focus on after being shipped acknowledges the existence of a relationship between a company and a customer even after the product is shipped. In doing so, Taguchi offers the product and process design community a decision model to view the world as holistic in nature, rather than fragmented.

We propose that Taguchi’s concept of “minimizing loss to society” [12] can readily be expanded upon as a framework for environmental awareness and more holistic decision making. An explanation of Taguchi’s concept of a “quality loss” function nicely describes what is sorely missing in organizations burdened by the prevailing style of management. Deming has described Taguchi’s loss function as “a better view of the world” [13].

To better appreciate the implications of water and rock logic, of parts and connections, and of Taguchi’s loss function consider the routine of cutting a piece of wood for a home improvement project (Figure 2). As an example, let’s say the piece is baseboard molding to fit between two existing pieces. We begin with a piece of molding which is too long and needs to be shortened. In rapid order, the required length is measured and the piece is marked for cutting. As a next step, a saw is readied.

Consider how many lines one typically would draw across the top face before making the cut. That is, instead of using short marks to indicate where to place the saw, how many lines would be drawn across the top face to guide the placement of the saw blade? Most often the solution is to use a single line. But, is this the correct answer? If not, what other answer could there be? While not immediately obvious, other answers might be “2 lines” or “3 lines,” if not more. What is a possible explanation for the “1 line” answer? Could it be that we would draw one line out of habit? Why is the habit not 2 lines, as in the standard industry use of manufacturing tolerances with an acceptable range? One suggestion is that the 1 line answer, a reference to a “target” length, is an indication of a strong intuitive sense of water logic - knowing what the piece of wood is

“part of,” knowing where “it came from,” and knowing where it “will lead to.” Such a perspective is likely when one is involved in a home improvement project and the connections are visible and immediate. Also obvious is the poor quality of the fit if the piece is too long or too short. The extra effort required to adapt the piece of wood, should it be too short or too long, represents Taguchi’s concept of quality loss, increasing continuously as the length misses the target by larger and larger amounts. Be it an unsightly gap in need of filler material or the presence of a bulge, the loss is finite and it is real. In this case the loss would be imparted to oneself.

Let’s revisit this wood cutting example in the context of a “present state” organization where rock logic dominates and “parts are parts.” The connections and the cumulative negative impact to others downstream will be far less obvious when the wood is cut using manufacturing tolerances, as in marking the piece with 2 lines indicating a lower specification limit, LSL, and an upper specification limit, USL (Figure 3). In this situation, the wood could be cut anywhere in between these lines and termed “good” since the length requirements would have been met. By contrast, note how easy it would be to intuitively appreciate the implications of “loss imparted” and act to minimize this loss when we are the next person in the flow, as if receiving our own work. Such would be the situation in a “future state” organization, where one would act with a sense of connections, consistent with water logic.

Johnson [14, 15] believes that business processes, especially in manufacturing settings, should be considered in the same way that the above authors view natural processes in a “future state” organization. He offers as a ponderable that what we see is a reflection of how we think. As a simple example, consider the response of a parent upon reading her child’s report card. Are the grades, low or high, an indication of the student, alone? Or, might it be possible that the grades are also a reflection of the local board of education, to name a few interdependent parts. How the parent responds to her child’s report card will reveal her understanding of the size of the child’s education system and the degree of interconnectedness of the components. Likewise, in a factory setting, the quality of a duct weld is a reflection of the welding system in which the welder resides. Johnson voices concerns that managerial accounting, with its focus on financial performance measures, enforces a mechanistic, linear perspective rather than a more holistic, systemic decision process. Such an accounting system is all the more likely to interpret a machinist’s actions to focus on “target” dimensions in a manufacturing setting as “non-value added,” since this “present state” system would see parts as parts, without quality loss incurring relationships. “Present state” managerial accounting systems are more likely to focus on how to allocate the costs for these “quality losses” across a company rather than question the origin of these losses, if they could be sensed at all.

## 2.2 Ecobusiness Thinking

Hawken et al., describe many companies that have successfully integrated their economic, environmental, and social goals. They propose a new business paradigm that might be summarized as companies providing the right products at the right time in the right amount, using the right processes, the right materials, and the right business model to consumers. This entails redesigning production and consumption cycles so they are based on “a new perception of value, a shift from the acquisition of goods as a measure of affluence to an economy where the continuous receipt of quality, utility, and performance promotes well-being” [16].

Hawken et al., describe four types of capital (human, financial, physical or manufactured, and natural) that are interconnected in a properly functioning economy. A company’s financial and physical capital is easily captured in its financial statements. However, the other two (human and natural) are not easily captured because they are less tangible. Therefore, they are not assigned value and are normally not included in financial statements. Therein lies some of the challenges for both businesses as they move toward natural capitalism and for the accounting profession so that financial statements reflect this new perspective – how these “soft assets” are accounted for and what non-financial disclosures are necessary to evaluate a company’s impact on its soft assets. Hawken et al., conclude that “the true bottom line is this: a society that wastes its resources wastes its people and vice versa. And both kinds of waste are expensive” [17].

Savory believes that a holistic perspective is not only possible, but also imperative in all business decisions. He began his work in the African Bushveld, where as a young man, he came to realize that the environment he loved was doomed. After a long struggle and many changes in his perspective, he pieced together a decision making process that “gives us the ability to design and to plan the future we want while ensuring that the environment can sustain it” [18]. The model is not much different from decision-making processes in large organizations. The main difference is including a long-term, sustainable imperative, which he refers to as a holistic goal, as an up-front assumption. This same model has been implemented in several business settings and has been adopted by a couple of forward-thinking higher learning institutions. We discuss the model in more detail in the following section.

The founder of the Natural Step Movement, Robert is a physician and one of Sweden’s leading oncologists. His work builds off of that of physicist and author Fritjof Capra, who focuses on the whole rather than the parts, as he discusses moving from reductionist (parts) thinking to systems thinking. Robert developed The Natural Step structure by asking well-known scientists, from a variety of areas to help identify a sustainability framework within which to apply systems thinking to all decisions. What emerged were four system conditions or scientific restrictions as presented by The Natural Step U.S. [19] and clarified by Burns [20]:

1. Materials from the earth’s crust must not systematically increase in nature (e.g. heavy metals, fossil fuels)
2. Persistent substances produced by society must not systematically increase in nature (e.g. PCBs, CFCs DDT)
3. The physical basis for the earth’s productive natural cycles and biological diversity must not be systematically deteriorated
4. There must be fair and efficient use of resources with respect to meeting human needs

Robert believes that there must be a “Compass” linking principles to details, enabling control over outcomes, and making sense of other tools, such as assessment and life-cycle costing [21]. To that end, the four system conditions lead to a number of principles that an individual or organization must have a reading on for every decision (they are referred to as back-casting and they mirror development of the holistic goal in Savory’s model):

1. Understand that you are part of the system
2. Envision the principles for the future (the above-mentioned system conditions)
3. Establish where you want to be
4. Identify what must be accomplished to achieve the desired end state
5. Evaluate if desired outcome is economically feasible
6. Determine indicators that will measure achievement of holistic goal

McDonough asserts that the main measure for productivity, the Gross National Product, allows for events such as the Exxon Valdez incident to be considered progress because economic indicators go up. He, along with his partner Braungart developed three principles for design that allow businesses to live within the laws of nature. The first, waste equals food, implies that any waste from production processes must be food for another production cycle or be biodegradable. Depend on current solar energy rather than on stored energy (fossil fuels) is the foundation of the second principle. There are immense opportunities during the design phase to make buildings, equipment, transport, and consumables more reliant on renewable energy. The final principle asks us to respect diversity. Thinking beyond the need for biodiversity, to McDonough, diversity means flexible designs that allow for regenerative wastes and buildings and equipment that with minimal effort may be converted to other uses rather than becoming waste in a landfill [22].

We see that the above individuals have taken systems thinking and thinking about thinking one step further to include society’s reliance on a healthy, regenerating ecosystem. To expand on the “from-this-to” sequence, we would now include “with what resources,” “with what impact,” and “at what social/ecological cost” to close the loop. When these questions are considered during the decision making process, the information needs may

expand, but the compass reading becomes truer.

### 3. Steps Toward Better Decision Making

We briefly outline two business concepts that either already have a sustainable perspective or might easily be adapted to include sustainability: the balanced scorecard and Savory's holistic resource management decision model. A balanced scorecard is developed around a set of metrics or perspectives and indicators that help an organization focus on performance indicators that have a forward-looking (and potentially) holistic focus. Savory's model is presented as a tool that enables organizations to implement a decision-making process based on a holistic goal or true north compass reading. We conclude this section by offering a view of ongoing activities within The Boeing Company to promote better thinking as a means to achieve better doing, which can be translated into minimizing losses to society and Boeing.

#### 3.1 Business Concepts

The balanced scorecard, developed by Kaplan and Norton [23] is one method to evaluate a company's performance from a more complete perspective. A balanced scorecard is a metric of performance measures that support an organization's strategy. In addition to financial measures, a balanced scorecard includes long-term, forward-looking perspectives (i.e. customer, business processes, employee learning and growth, and environmental) that are necessary to ensure a sustainable and profitable future. The set of measures traditionally fall into four categories considered essential for success: financial, customer, internal business processes, and learning and growth. Hence, businesses use a balanced scorecard to evaluate their ability to provide quality output with fewer resources, eliminate non-value added efforts, align products or services provided with customer priorities and expectations, track progress, evaluate process changes, continually improve, and increase accountability.

Other entities or individuals can easily adapt the BSC concept. For example, as an exercise, participants in the Cal Poly Land Seminar developed a BSC for the Cal Poly Center for the Environment at Swanton Pacific Ranch. This BSC included perspectives (educational, environmental, economical, and societal) that encourage Center planners to develop, and then monitor, holistic goals. Once performance indicators are determined for each perspective, the next step would be to develop targets and initiatives for each objective. A holistic, systems-thinking balanced scorecard would also include environmental, societal, and cultural measures that truly allow organizations to receive feedback on how they are doing and identify trends in the measures that might indicate they are moving off-course.

Given the potential for including these effects, a critical limitation in using the balanced scorecard remains the need for measurements of the progress towards achieving the balanced holistic goals and staying on-course. For example, consider the challenges of measuring the impact of environmental damage on the generations that follow us, in comparison to the costs of alternative options for actions today. "Present state" use of the balanced scorecard, without an appreciation of the implications of Taguchi's quality loss function, will surely overlook and underestimate many downstream impacts. "Future state" use of the balanced scorecard concept will recognize the limitations of the belief system that suggests that "if you cannot measure it, you cannot manage it." The *better thinking about thinking* in these organizations will be guided by Deming's admonition that the most important numbers are unknown and unknowable. In keeping with this understanding, numbers that are deemed measurable are themselves the results of acknowledged and documented assumptions that are updated as needed. This organizational thinking paradigm helps make better sense of information, leading to the measurable benefits of higher profitability and the immeasurable benefits of greater customer loyalty and higher employee morale.

Savory's decision model (Figure 4) illustrates the complexity of a decision model that considers environmental impact. Sam Bingham describes a ranch community's effort to implement the Holistic Management model in Colorado's high deserts, graphically illustrating the six steps to follow while validating a decision:

1. Honor the ecosystem as a whole
2. Strengthen the weak link in the operation
3. Address causes, not symptoms
4. Give the best marginal reaction per dollar
5. Represent a conscientious use of energy and nonrenewable wealth
6. Respect society and culture

The first step in Savory's Holistic Management model is to identify the whole under management— those affected and the resources (both monetary and natural) involved. The second step is to develop a value-based holistic goal, which is used for the basis of all decisions. For example, all parties that impact the ecological health of Colorado's high deserts and those that are working to restore that ecosystem would work together to identify what they value about a healthy ecosystem. After considering the ecosystem processes and the tools that are available for managing the ecosystem, each recommendation is evaluated using specific guidelines. These guidelines consider economic, social, and ecological impacts, which are reflective of the emphasis of the triple bottom line. The feedback loop, which is similar to Deming's "PDSA" learning cycle, is an important component in that any implemented solution must be revisited to determine if the results are as anticipated. Information from the feedback loop helps individuals in anticipate variation in future outcomes to gain insight on possible outcomes.

### 3.2 Holistic Thinking from The Boeing Company

Over the past 20 years, the practice of managing process variation with respect to target values has represented a valuable alternate practice when compared to industry norms. Instead of judging the goodness of a given process, or parts, in terms of rock logic, better sense of information is being made within The Boeing Company.

Consider the ultimate quality goal of a "present state" organization - 100% good parts or *zero* defects. A closer evaluation of this goal reveals that the practice of part thinking (as in the part is *good* enough) runs counter to target thinking. In recent years, a Boeing team applied Taguchi's loss function thinking to achieve a remarkable gain in hardware braze quality (zero defective braze fillets in one braze cycle) when fabricating rocket propulsion hardware. The hardware consists of a flat plate with 628 holes of equal size, in which 628 round posts are brazed in place. The successful brazing of this hardware creates 1,256 braze fillets, 2 per joint – one at the interface of the post with the top face of the plate and one at the interface with the bottom face.

The Integrated Product and Process Team approached this hardware design (Figure 5) by abandoning the traditional expectation that 2 to 3 braze cycles would be required to complete all 1,256 fillets. With the traditional practice, a wasteful time-consuming second (sometimes third) brazing operation was necessary to complete the brazing of all 1,256 fillets. Using traditional thinking, as in thinking about "parts" with the belief that everything within manufacturing tolerances is of equal quality, this was the best the organization knew how to do. By making better sense of this information, under the guidance of water logic and Taguchi's loss function, the team decided to explore the possibility that additional braze cycles could be eliminated by shifting the thinking of the team from "parts" to "relationships," that is, from an emphasis on rock logic to an emphasis on water logic. Using the information provided by a water logic perspective, the team could more readily account for the "quality losses." They predicted that all 1,256 fillets could be achieved in one braze cycle, with the unheard of result of 100% first pass braze quality. "Future state" thinking was used to focus on managing the process variation with respect to the target values for both the diameter of the 628 holes and the outer diameter of the 628 posts. Although more time and effort was required to manage the variation of these dimensions in this manner, the added attention to detail on relationships eliminated the need for a far more expensive second and third braze cycles. To date, 100% first pass braze quality results have been repeated on a routine basis, which reduces the use of additional resources.

## 4. Summary and Conclusions

We have attempted to illustrate the similarities between well-known systems thinkers, whose teachings have been adopted by organizations to varying degrees, and the leaders of ecobusiness thinking. Both groups are cognizant of the relationships and the importance of considering those relationships during any decision making process. Key to making informed decisions in a business organization is identifying "true north" for the

company, which includes considering future system requirements that must exist to support future success. Once a set of system criteria and an understanding of the relationships and potential consequences exists, we propose that individuals will be more easily able to identify what information is needed to make fully informed, sound decisions.

Our conclusion is that individuals, and organizations, would benefit from *better thinking about thinking*, that is, thinking that promotes better discovery and better decision-making. Discovery of opportunities, discovery of connections, discovery of systemic effects, are but a few forms of essential discovery about relationships. Relationships between employees, between companies and suppliers, customers, and the environment are not as visible as they could be. If one cannot see connections, then one can see only parts. As such, our lives and the world we live in are viewed as sets of fragmented pieces in a deterministic world. Without a better sense of connections, of water logic, we will not be able to make better sense of information. In a fragmented world, we tend not to see things coming and, consequently, experience problems without warning. Adding to this scenario of disconnections, we then act to impart blame to elements of the system instead of to the system itself. Lacking this sense of connections, such blame may well be imposed on the student in a classroom or on the welder on a shop floor. When we are aware of connections, we can anticipate. Such anticipation provides early warning of impending trouble and the ability to make better sense of information. Better thinking about information offers the ability to uncover these opportunities for investment and offer us previously unforeseen opportunities to manage costs and quality losses.

#### Acknowledgements

The authors would like to thank Alan Winlow, Tom Johnson, and Allan Savory for helping them to make the connections that we view as vital to making better sense of information in the pursuit of each organization's "true north."

#### References

- [1] Deming, W. Edward; The New Economics, MIT Press, Cambridge, MA, 1993.
- [2] Deming, W. Edward; On the Theory of Least Squares, Wiley & Sons, New York, 1934.
- [3] Deming, W. Edward; The New Economics, MIT Press, Cambridge, MA, 1993.
- [4] Ibid.
- [5] Deming, W. Edward; Out of the Crisis, MIT Press, Cambridge, MA, 1986.
- [6] Delavigne, Kenneth and J. Daniel Robertson; Deming's Profound Changes: When Will the Sleeping Giant Awaken? Prentice-Hall, Englewood Cliffs, NJ, 1994.
- [7] Mann, Nancy; The Keys to Excellence: The Story of the Deming Philosophy, Prestwick Books, Cheswold, DE, 1986.
- [8] Deming, W. Edward; The New Economics, MIT Press, Cambridge, MA, 1993.
- [9] Ibid.
- [10] de Bono, Edward; Water Logic. The Alternative to I am Right You are Wrong, Viking Press, London, 1993.
- [11] Taguchi, Genichi; Introduction to Quality Engineering, Asian Press Organization, 1983.
- [12] Ibid.
- [13] Deming, W. Edward; Out of the Crisis, MIT Press, Cambridge, MA, 1986.
- [14] Johnson, H. Thomas; Relevance Regained: From Top-down Control to Bottom-up Empowerment, The Free Press, New York, 1992.
- [15] Johnson, H. Thomas and Anders Broms; Profit Beyond Measure: Extraordinary Results through Attention to Work and People, The Free Press, New York, 2000.
- [16] Hawken, Paul, Amory Lovins, L. Hunter Lovins; Natural Capitalism: Creating the Next Industrial Revolution, Little Brown and Company: Boston, MA, 1999, page 10.
- [17] Ibid, page 55.
- [18] Savory, Allan and Jody Butterfield; Holistic Management: A New Framework for Decision Making, Island Press: Washington, DC, 1999, page 3.

- [19] Anonymous; The Natural Step, <<http://www.sustainable.doe.gov/business/natural.shtml>>, last updated July 27, 2000, accessed, June 12, 2002.
- [20] Burns, Susan; The Natural Step: A Compass for Environmental Management Systems, Corporate Environmental Strategy Volume 6, Issue 4, Pages 329-342, 1999, Available online at: <http://www.naturalstrategies.com/publications/sb-tns-compass-ems.pdf>, accessed, June 10, 2002.
- [21] Robert, Karl-Henrick; The Ecology of Business, Bristol (UK) Schumacher Lectures, October, 1995, available online at: [http://www.schumacher.org.uk/transcripts/schumlec95\\_Bri\\_TheEcologyOfBusiness\\_KHRobert.pdf](http://www.schumacher.org.uk/transcripts/schumlec95_Bri_TheEcologyOfBusiness_KHRobert.pdf), accessed, June 10, 2002.
- [22] McDonough, William; Design, Ecology, Ethics, and the Making of Things, A Centennial Sermon, The Cathedral of St. John the Divine, NY, NY, February 7, 1993, available online at: <http://www.mcdonough.com/Sermon.pdf>, accessed, June 10, 2002.
- [23] Kaplan, Robert and David Norton; The Balanced Scorecard: Translating Strategy into Action, Harvard Business School: Cambridge, MA, 1996.
- [24] Bingham, Sam; The Last Ranch: A Colorado Community and the Coming Desert, Pantheon Books, NY, 1996.

Figure 1. "Production viewed as a system," as introduced by Dr. Deming to Japanese engineers and managers in the summer of 1950. (Deming, 1993)

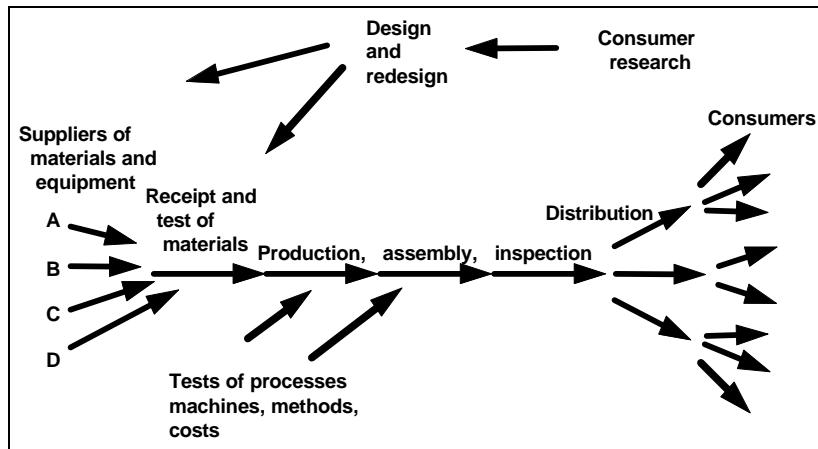

**Figure 2. Marking a piece of wood before cutting it to size.**

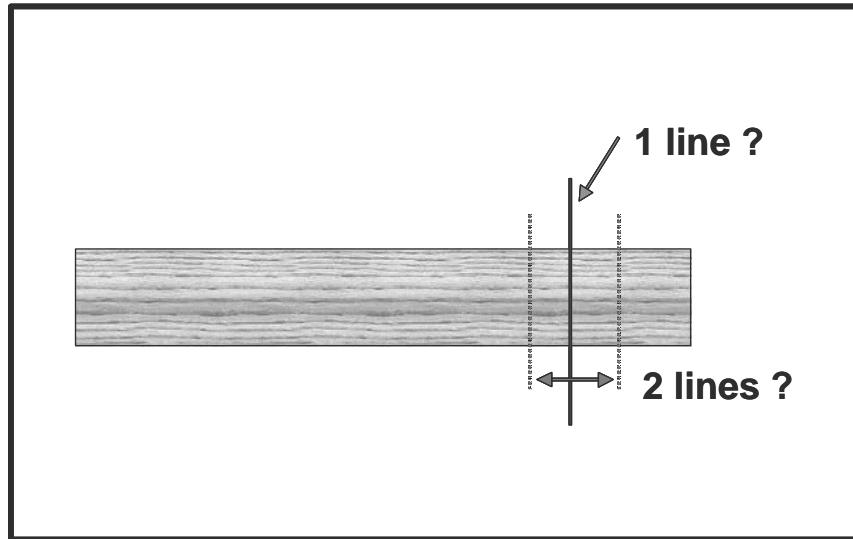

Figure 3. "Quality Loss Function" as introduced by Taguchi in Japan in the 1950's.

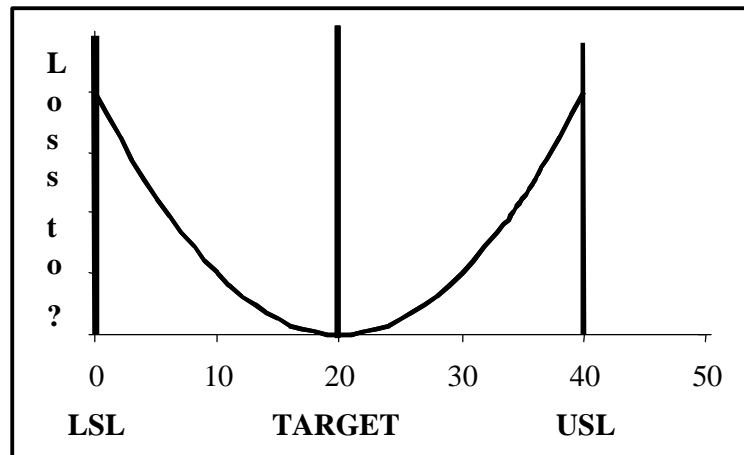

Figure 4. "Holistic Resource Management Model" (Reprinted with Savory's permission)

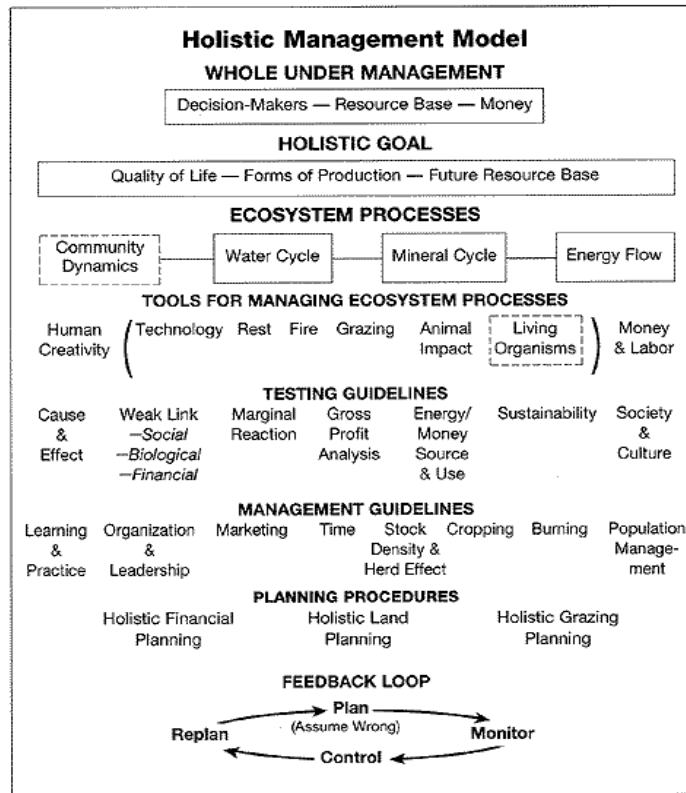

Figure 5. Cross-section of hardware assembly showing 2 braze fillets per joint.

